

Screw plug immersion heaters

HEATING GASES

HEATING LIQUIDS

MAINTAINING A CONTINUOUS TEMPERATURE



The screw plug immersion heaters by CETAL are designed and manufactured as a standard range or according to customer specifications. Reliability and robustness are key drivers for our engineers.

Advantages

- Large range of materials and options according to customer process and application
- Standard range available
- Benefit from CETAL's 50 years of experience as designer and manufacturer!
- The end-to-end control of the design and production chain allows us to deliver a product which suits your process perfectly

The screw plug immersion heaters consist of one, three or six heating elements which are assembled on a brass, steel or stainless steel plug.

Applications

- Heating of circulating or static fluids
- Heating of:
 - Static or circulating water
 - Rinsing baths
 - Oils
 - Acids
 - Circulating thermal fluids
 - Heavy oil
 - Air or gas
- Mounted in tanks, cisterns, boilers or circulation heaters, etc.
- Power from 100 W to 35 kW
- Designed for pressure up to 15 bars

Industrial sectors

- Petrochemicals
- Chemical industry
- Food industry
- Plastics
- Aeronautics
- Etc.

Standard immersion heaters

CETAL offers a standard range of screw plug immersion heaters. See page 6.

Bespoke heaters on request

You could not find any standard immersion heater for your application? After customer specification analysis, our engineers will drive you to the best solution for your process.

Temperature control

Temperature sensors (thermostat, limiter, thermocouple or PT100) in the medium (process control) or on the heating elements (safety control).

CETAL heating elements



1. Connection terminals
2. Tube
3. Insulation : magnesia oxyde (Mg O), to secure optimized heat transfer and electrical insulation.
4. Resistance wire: Made of Nickel Chrome 80/20, it is the active part of the heating element (Joule effect)
5. Cold length
6. Sealing material: Keeps out external moisture. Different types (silicon, resins, cement) are used depending on the industrial application, the external medium and temperature.
7. Output insulation: Made of steatite ou corundum, it provides dielectric insulation (creepage distance, distance in the air).

CETAL manufactures their own heating elements which are the key components (active parts) of all electric heating systems. The design is defined according to customer specifications. The watt density, tube diameter and the tube sheath are chosen to optimize the reliability and robustness (corrosion, temperature) of **CETAL** equipments.

Manufacturing

The electric heating resistance (sheathed heating resistance) consists of a Nickel Chrome 80/20 resistance wire placed in the middle of a protective tube (sheath). It is filled with high-quality magnesia oxyde enabling the optimized heat transfer and electrical insulation. Each side of the heating element has a cold length depending on the type of use which is used for wiring.

Design of your immersion heater

Input data

- A. Application
- B. Type of plug
- C. Type of fluid
- D. Pressure
- E. Inlet and outlet temperature
- F. Flow rate (mass or volume)
- G. Environment of operation
- H. Voltage (V)
- I. ATEX/IECEX or not, temperature class
- J. Max. immersion length
- K. Directives, standards, construction codes

CETAL thermal design and offer

Design procedure to optimize your product

1. Power
2. Type of plug
3. Watt density (W/cm²)
4. Number of heating elements
5. Material / Tube diameter
6. Type and number of baffles
7. Type of assembly (welding or brazing)
8. Heating length (HL)
9. Cold length (NC)
10. Immersion length (CL)
11. Temperature control and safety, type of sensor
12. Connecting box / Cable gland
13. Other components
14. Quotation: price and delivery time

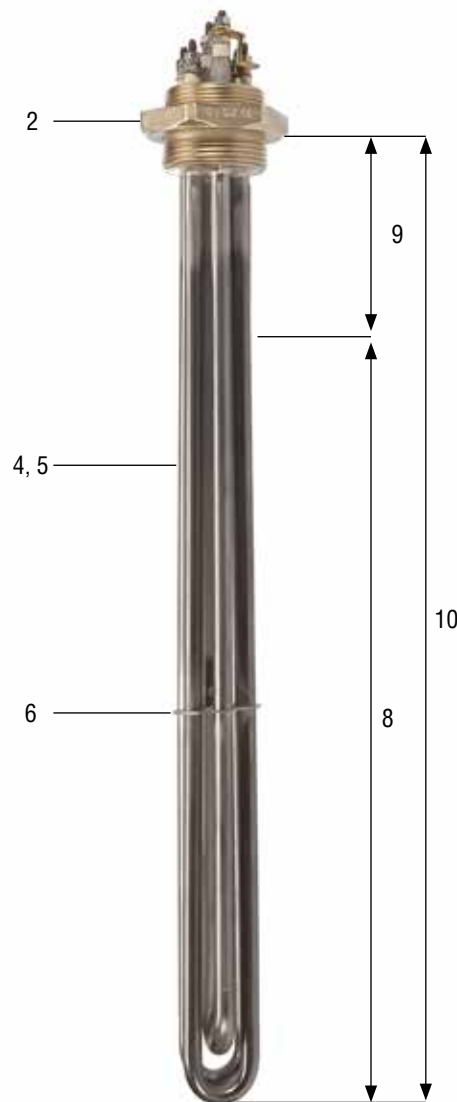

Standard
range
page 6

Benefit from the CETAL advantages!



Design and manufacturing experts since 50 years!



Calculation and design tools specifically developed for industrial heating applications



End-to-end control of design and production chain for products which suit your process perfectly



Benefit from the CETAL know-how to optimize your process and reduce costs!

Technical data

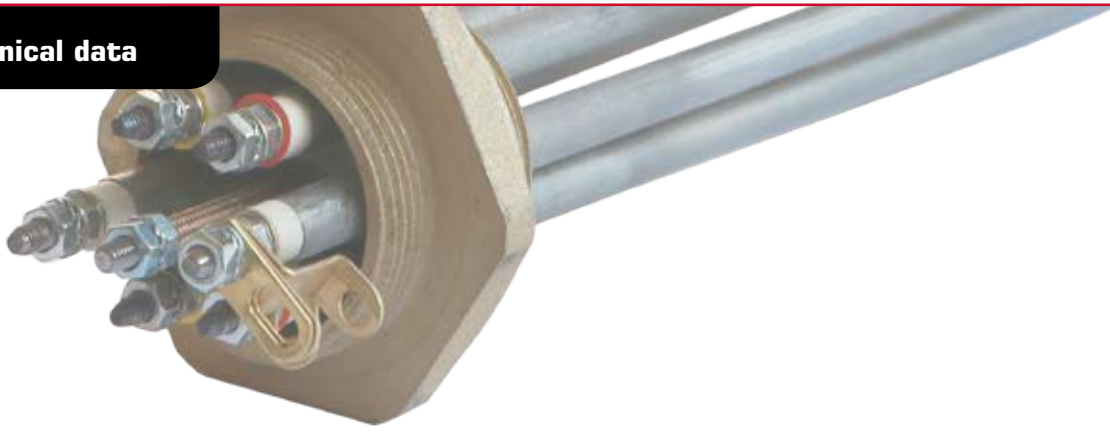

Temperature

- Fluid temperature <110°C, no offset
- Fluid temperature >110°C, offset between the protecting box and the tank is recommended

Pressure

Brazed connection up to 15 bars of fluid pressure.

Tube materials

- Stainless steel
 - AISI 321 (1.4541)
 - AISI 316L (1.4404)
 - AISI 309 (1.4828)
- High-performance nickel alloys
 - Incoloy 800 (1.4876)
 - Incoloy 825 (2.4858)
 - Inconel 600 (2.4816)
- Others
 - Titanium
 - Copper (nickel-plating on request)
- Specific coating
 - Teflon™ (PTFE)
 - Halar (ECTFE)

Tube diameter

- 6.5 / 8.5 / 10 / 13.5 / 16 mm

Plug

- Common diameters: ½", ¾", 1", 1¼", 1½", 2", 2½", M45, M77
- Materials: Brass, stainless steel or steel on request
- Connection: brazed or welded, depending on the application
- **Options:** Seal and sealing nut adapted to the plug.

Mounting

- Vertical or horizontal position

Terminals

- Threaded steel or stainless steel rod: M4x0.7 (tubes ø6.5, Ø8.5 and Ø10), M5x0.8 (tubes ø13.5), M6x1 (tubes ø16).
- Plain rod, flat terminal, tab or cable on request
- Sealing and electrical insulation through epoxy resin or silicone, and ceramic end seal.

Electrical

- Voltage: VAC or VCC
- Cabling according to main voltage VAC/VCC 1PH + N or 3PH
- For heating power from 100 W to 35 kW

Standard documentation

- Heater wiring diagram
- Instruction manual

On-request documentation

- Certificate of conformity to the order
- Supplied according to directives, standard and construction code
- Material certificate 3.1 acc. to NF EN 10204

Certifications (if required)

- According to standard to comply with
- EAC CU TR, c CSA us



Options

Protective enclosures



- Large range of enclosures, different sizes, aluminum, polyamide or steel
- Electrical degree of protection from IP40 to IP66
- Polyamide or brass cable gland, adapted diameter, or simple grommet

Temperature control

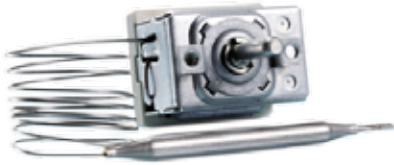

Large range of control or safety thermostats, thermocouples and PT100 sensors, from -35 to 450°C, allowing optimum temperature control. Temperature measurement via immersion sleeve of adapted length or directly welded on the heating element for more accuracy.

Assembly parts



Seal and sealing nut adapted to the plug, welding ring

Options for standard screw plug immersion heaters

- Standard control thermostats are only available with aluminum enclosure
 - 1PH 0/40°C
16A/250V ~ or 10A/400V ~
 - 1PH 30/90°C
16A/250V ~ or 10A/400V ~
 - Including immersion sleeve and additional cable gland on aluminum enclosure
- Compact polyamide enclosure, for 1PH immersion heater without thermostat (M45 / 1"½)
- Seal and fastening nut kit for threading: 1"½, M45, 2"½, M77
- Welding ring: 1"½, M45, 2"½, M77

Complementary products



Standard power control panels
CETAL offers a large range of cost-effective power control panels.



Vessels for circulation heaters
We provide complete circulation heaters on request.



Standard screw plug immersion heaters

Plug: 1"½ (ref 49BS) or M45 (ref 45BS), brass

Connecting box: aluminum IP55 95 x 95 x 80, no offset

Max. operating temperature: 110 °C

ø tube: 8.5 mm

Terminal: threaded M4 x 0.7

Cold length: 40 mm min.

Brazed, max pressure: 15 bars



Plug: 1"½ or M45, brass					
Static oils, air, heavy fuel oil					
Material	Power (W)	Watt dens. (W/cm ²)	Max. IL* (mm)	Voltage	Reference**
316L	250	2.5	240	1PH 230V	TPV-xxBS-002C-C2B-1X
316L	333	2.5	305	1PH 230V	TPV-xxBS-003C-C2B-1X
316L	500	2.5	430	1PH 230V	TPV-xxBS-005C-C2B-1X
316L	666	2.5	555	1PH 230V	TPV-xxBS-006C-C2B-1X
316L	1000	2.5	430	1PH 230V	TPV-xxBS-010C-C2B-1X
316L	750	2.5	240	3PH 230/400 V	TPV-xxBS-007A-C2B-1X
316L	1000	2.5	305	3PH 230/400 V	TPV-xxBS-010A-C2B-1X
316L	1500	2.5	430	3PH 230/400 V	TPV-xxBS-015A-C2B-1X
316L	2000	2.5	555	3PH 230/400 V	TPV-xxBS-020A-C2B-1X
316L	3000	2.5	805	3PH 230/400 V	TPV-xxBS-030A-C2B-1X
316L	4000	2.5	1055	3PH 230/400 V	TPV-xxBS-040A-C2B-1X

Plug: 1"½ or M45, brass					
Circulating oils, glycoled water, aqueous solution					
Material	Power (W)	Watt dens. (W/cm ²)	Max. IL* (mm)	Voltage	Reference**
316L	333	4	210	1PH 230V	TPV-xxBS-003C-C4B-1X
316L	500	4	290	1PH 230V	TPV-xxBS-005C-C4B-1X
316L	666	4	365	1PH 230V	TPV-xxBS-006C-C4B-1X
316L	1000	4	290	1PH 230V	TPV-xxBS-010C-C4B-1X
316L	1500	4	405	1PH 230V	TPV-xxBS-015C-C4B-1X
316L	2000	4	520	1PH 230V	TPV-xxBS-020C-C4B-1X
316L	1000	4	210	3PH 230/400 V	TPV-xxBS-010A-C4B-1X
316L	1500	4	290	3PH 230/400 V	TPV-xxBS-015A-C4B-1X
316L	2000	4	365	3PH 230/400 V	TPV-xxBS-020A-C4B-1X
316L	3000	4	525	3PH 230/400 V	TPV-xxBS-030A-C4B-1X
316L	4500	4	760	3PH 230/400 V	TPV-xxBS-045A-C4B-1X
316L	6000	4	990	3PH 230/400 V	TPV-xxBS-060A-C4B-1X

* Immersion length

** Plug reference: 1"½ (ref 49BS) or M45 (ref 45BS)



Standard screw plug immersion heaters

Plug: 1"1/2 or M45, brass

Domestic hot water

Material	Power (W)	Watt dens. (W/cm ²)	Max. IL* (mm)	Voltage	Reference**
316L	2250	8	240	3PH 400 V	TPV- xxBS -022B-C8B-1X
316L	3000	8	305	3PH 400 V	TPV- xxBS -030B-C8B-1X
316L	4500	8	430	3PH 400 V	TPV- xxBS -045B-C8B-1X
316L	6000	8	555	3PH 400 V	TPV- xxBS -060B-C8B-1X
316L	9000	8	805	3PH 400 V	TPV- xxBS -090B-C8B-1X
316L	12000	8	1055	3PH 400 V	TPV- xxBS -120B-C8B-1X

Plug: 1"1/2 or M45, brass

Industrial water, domestic hot water

Material	Power (W)	Watt dens. (W/cm ²)	Max. IL* (mm)	Voltage	Reference**
Incoloy 800	1500	10	335	1PH 230V	TPV- xxBS -015C-ZAB-1X
Incoloy 800	2000	10	430	1PH 230V	TPV- xxBS -020C-ZAB-1X
Incoloy 800	2500	10	525	1PH 230V	TPV- xxBS -025C-ZAB-1X
Incoloy 800	3000	10	615	1PH 230V	TPV- xxBS -030C-ZAB-1X
Incoloy 800	4500	10	335	3PH 230/400 V	TPV- xxBS -045A-ZAB-1X
Incoloy 800	6000	10	430	3PH 230/400 V	TPV- xxBS -060A-ZAB-1X
Incoloy 800	7500	10	525	3PH 230/400 V	TPV- xxBS -075A-ZAB-1X
Incoloy 800	9000	10	615	3PH 230/400 V	TPV- xxBS -090A-ZAB-1X
Incoloy 800	12000	10	805	3PH 230/400 V	TPV- xxBS -120A-ZAB-1X

* Immersion length

** Plug reference: 1"1/2 (ref **49BS**) or M45 (ref **45BS**)

Options

- Standard control thermostats are only available with aluminum enclosure
 - 1PH 0/40°C
16A/250V ~ or 10A/400V ~
 - 1PH 30/90°C
16A/250V ~ or 10A/400V ~
 - Including immersion sleeve and additional cable gland on aluminum enclosure
- Compact polyamide enclosure, for 1PH immersion heater without thermostat
- Seal and fastening nut kit for threading: 1"1/2, M45
- Welding ring : 1"1/2, M45



Standard screw plug immersion heaters

Plug: 2"½ (ref 76BS) or M77 (ref 77BS), brass

Connecting box: aluminum IP55 110 x 110 x 105, no offset

Max. operating temperature: : 110 °C

ø tube : 16 mm

Terminal: threaded M6 x 1

Cold length: 70 mm min.

Brazed, pressure max : 15 bars



Plug: 2"½ or M77, brass					
Static oils, air, heavy fuel oil					
Material	Power (W)	Watt dens. (W/cm²)	Max. IL* (mm)	Voltage	Reference**
316L	1000	2.5	480	1PH 230V	TPV-xxBS-010C-C2E-2X
316L	1500	2.5	375	1PH 230V	TPV-xxBS-015C-C2E-2X
316L	2000	2.5	475	1PH 230V	TPV-xxBS-020C-C2E-2X
316L	2500	2.5	575	1PH 230V	TPV-xxBS-025C-C2E-2X
316L	3000	2.5	675	1PH 230V	TPV-xxBS-030C-C2E-2X
316L	3000	2.5	480	3PH 230/400 V	TPV-xxBS-030A-C2E-2X
316L	4500	2.5	675	3PH 230/400 V	TPV-xxBS-045A-C2E-2X
316L	6000	2.5	875	3PH 230/400 V	TPV-xxBS-060A-C2E-2X
316L	7500	2.5	1075	3PH 230/400 V	TPV-xxBS-075A-C2E-2X
316L	9000	2.5	1275	3PH 230/400 V	TPV-xxBS-090A-C2E-2X
316L	12000	2.5	1670	3PH 230/400 V	TPV-xxBS-120A-C2E-2X

Plug: 2"½ or M77, brass					
Circulating oils, glycoled water, aqueous solution					
Material	Power (W)	Watt dens. (W/cm²)	Max. IL* (mm)	Voltage	Reference**
316L	1000	4	330	1PH 230V	TPV-xxBS-010C-C4E-2X
316L	1500	4	455	1PH 230V	TPV-xxBS-015C-C4E-2X
316L	2000	4	325	1PH 230V	TPV-xxBS-020C-C4E-2X
316L	2500	4	390	1PH 230V	TPV-xxBS-025C-C4E-2X
316L	3000	4	450	1PH 230V	TPV-xxBS-030C-C4E-2X
316L	3000	4	330	3PH 230/400 V	TPV-xxBS-030A-C4E-2X
316L	4500	4	455	3PH 230/400 V	TPV-xxBS-045A-C4E-2X
316L	6000	4	575	3PH 230/400 V	TPV-xxBS-060A-C4E-2X
316L	7500	4	700	3PH 230/400 V	TPV-xxBS-075A-C4E-2X
316L	9000	4	825	3PH 230/400 V	TPV-xxBS-090A-C4E-2X
316L	12000	4	1075	3PH 230/400 V	TPV-xxBS-120A-C4E-2X
316L	15000	4	1325	3PH 230/400 V	TPV-xxBS-150A-C4E-2X

Plug: 2"½ or M77, brass					
Domestic hot water					
Material	Power (W)	Watt dens. (W/cm²)	Max. IL* (mm)	Voltage	Reference**
316L	9000	8	480	3PH 400 V	TPV-xxBS-090B-C8E-2X
316L	13500	8	675	3PH 400 V	TPV-xxBS-135B-C8E-2X
316L	18000	8	875	3PH 400 V	TPV-xxBS-180B-C8E-2X
316L	22500	8	1075	3PH 400 V	TPV-xxBS-225B-C8E-2X
316L	27000	8	1275	3PH 400 V	TPV-xxBS-270B-C8E-2X
316L	36000	8	1670	3PH 400 V	TPV-xxBS-360B-C8E-2X

* Immersion length

** Plug reference: 2"½ (ref 76BS) or M77 (ref 77BS)



Standard screw plug immersion heaters

Plug: 2"½ or M77, brass					
Industrial water, Domestic hot water					
Material	Power (W)	Watt dens. (W/cm²)	Max. IL* (mm)	Voltage	Reference**
Incoloy 800	1500	8	265	1PH 230V	TPV- xxBS -015C-Z8E-2X
Incoloy 800	2000	8	330	1PH 230V	TPV- xxBS -020C-Z8E-2X
Incoloy 800	2500	8	390	1PH 230V	TPV- xxBS -025C-Z8E-2X
Incoloy 800	3000	8	455	1PH 230V	TPV- xxBS -030C-Z8E-2X
Incoloy 800	4500	8	265	3PH 230/400 V	TPV- xxBS -045A-Z8E-2X
Incoloy 800	6000	8	330	3PH 230/400 V	TPV- xxBS -060A-Z8E-2X
Incoloy 800	7500	8	390	3PH 230/400 V	TPV- xxBS -075A-Z8E-2X
Incoloy 800	9000	8	455	3PH 230/400 V	TPV- xxBS -090A-Z8E-2X
Incoloy 800	10000	8	495	3PH 230/400 V	TPV- xxBS -100A-Z8E-2X
Incoloy 800	12000	8	575	3PH 230/400 V	TPV- xxBS -120A-Z8E-2X
Incoloy 800	15000	8	700	3PH 230/400 V	TPV- xxBS -150A-Z8E-2X
Incoloy 800	18000	8	825	3PH 230/400 V	TPV- xxBS -180A-Z8E-2X
Incoloy 800	9000	12	330	3PH 400 V	TPV- xxBS -090B-ZCE-2X
Incoloy 800	12000	12	410	3PH 400 V	TPV- xxBS -120B-ZCE-2X
Incoloy 800	15000	12	495	3PH 400 V	TPV- xxBS -150B-ZCE-2X
Incoloy 800	18000	12	575	3PH 400 V	TPV- xxBS -180B-ZCE-2X
Incoloy 800	20000	12	630	3PH 400 V	TPV- xxBS -200B-ZCE-2X
Incoloy 800	24000	12	745	3PH 400 V	TPV- xxBS -240B-ZCE-2X
Incoloy 800	30000	12	910	3PH 400 V	TPV- xxBS -300B-ZCE-2X
Incoloy 800	36000	12	1045	3PH 400 V	TPV- xxBS -360B-ZCE-2X

* Immersion length

** Plug reference: 2"½ (ref **76BS**) or M77 (ref **77BS**)

Options

- Standard control thermostats are only available with aluminum enclosure
 - 1PH 0/40°C
16A/250V ~ or 10A/400V ~
 - 1PH 30/90°C
16A/250V ~ or 10A/400V ~
 - Including immersion sleeve and additional cable gland on aluminum enclosure
- Seal and fastening nut kit for threading: 2"½, M77
- Welding ring : 2"½, M77

All CETAL products can be adapted to your specifications.

Contact us!

